



Pan

Dimensional inspection of vials

The Vimec Pan inspection system is designed for dimensional inspection of borosilicate glass vials. The Pan system is installed in the forming machine and inspects the top of the vial, while the vial is held in the machine chuck.

Inspection principle

The vial is presented to the Pan system while it is held in the chuck of the forming machine. During the rotation of the chuck, multiple images of the top of the vial are taken by the Pan system. Reject criteria can be set on the dimensional aspects of the vial according to the customer requirements. The Pan system will provide a reject signal to trigger the reject unit if the vial dimensions are not within the tolerances.



Screen shot of image by Pan system

The Pan inspection system has measurements for threaded- and non threaded vials.

Schematic overview of measurements for vials

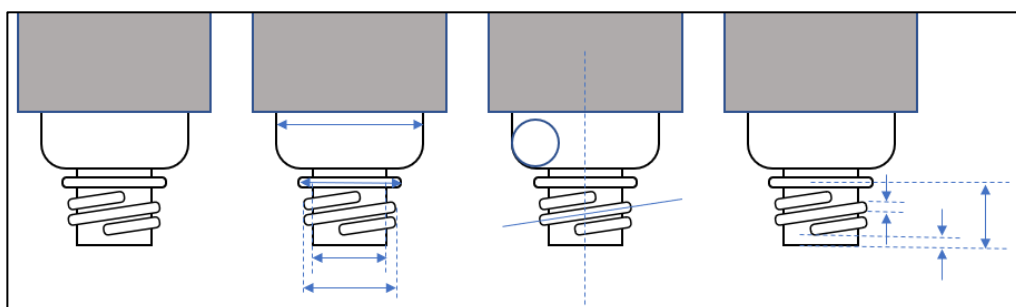
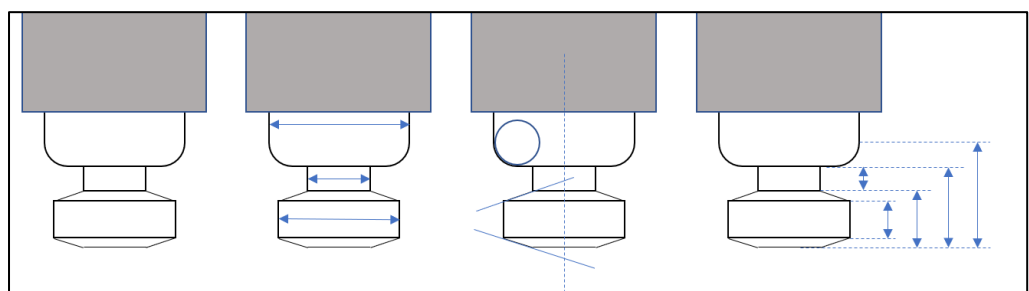

Schematic overview of measurements for threaded vials



Leading in glass inspection & monitoring solutions

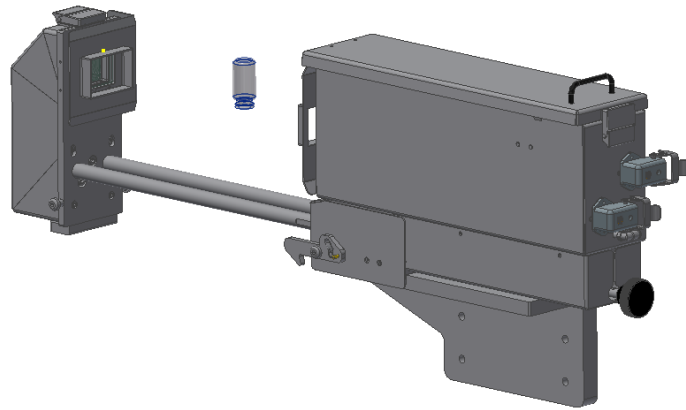

Schematic drawing of Pan system

Key figures:



60 parts per minute



1 camera



ISO size vials



In forming machine



Production insight



Vimec VCenter Software

Vimec Applied Vision Technology B.V.

With over 30 years experience in the specific market of packaging glass, we are dedicated to design, build and validate visual inspection systems. Vimec offers a multitude in measurement possibilities to cover all your inspection needs.

Interested?

Contact us for more information!



+31 (0)40 – 255 06 07



sales@vimec.nl



www.vimec.nl

*Vimec Applied Vision Technology B.V.
proud member of **Kestrel Vision Group***

