



Pandora

Dimensional inspection of vial bottom

The Pandora inspection system is designed for in line dimensional inspection of the bottom of vials:

- Bottom thickness
- Bottom concavity

The inspection system consists of an optical probe, horizontal sliding unit and a chromatic confocal sensor.

Inspection principle

The optical probe and the slide are mounted to the back of an indexed transport line as depicted in the image below. The sensor measures the distance to the first reflective surface (outer wall of the vial) and the second reflective surface (inner wall of the vial). The abbe-number and the refractive index of the glass are used to accurately determine the thickness of the bottom.

This measurement is a point measurement. To be able to measure the concavity the sensor is moved across the bottom of the vial and during the movement multiple point measurements are performed to create a profile.

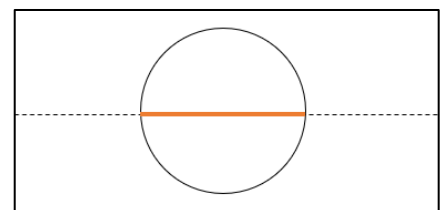
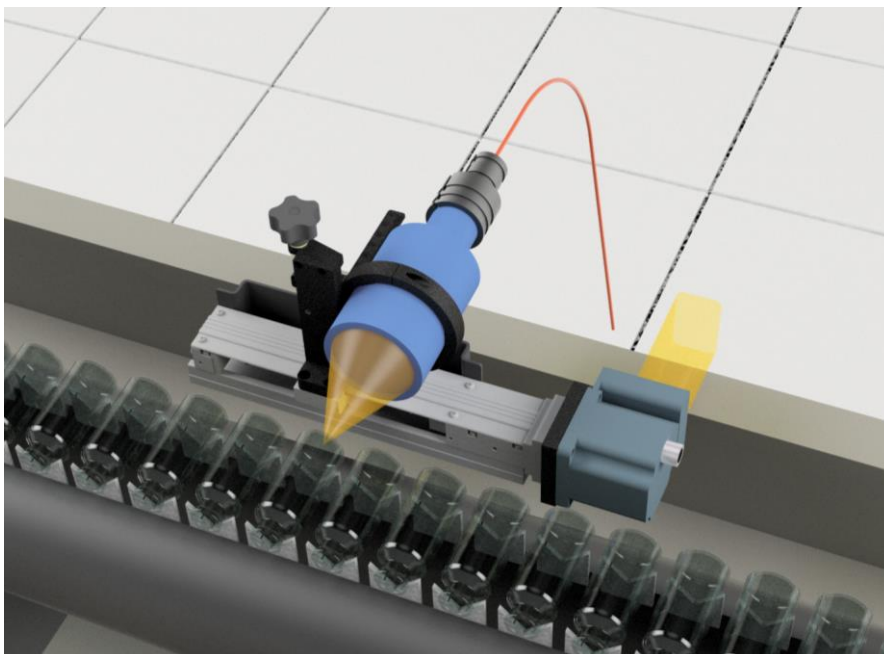
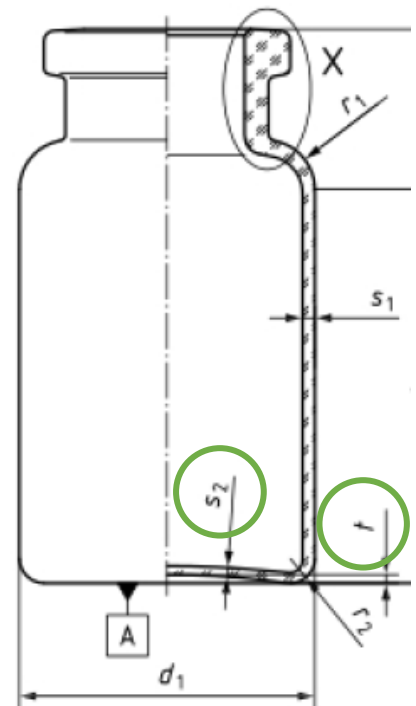

System overview

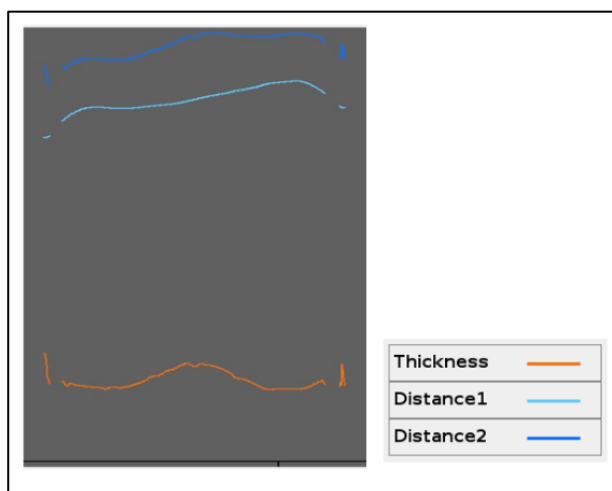

Bottom thickness

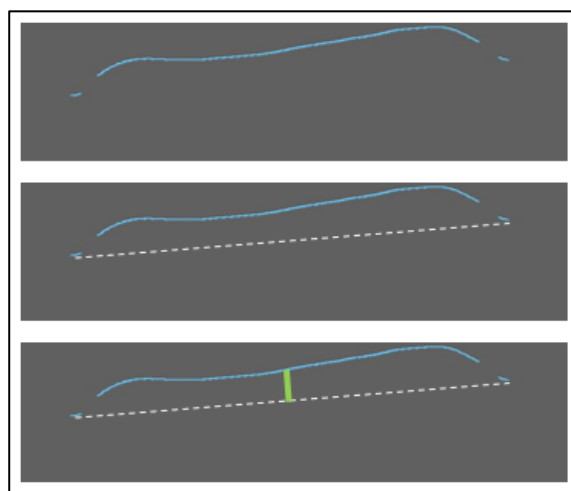

Bottom concavity

Key figures



Max. 120 parts per minute



Chromatic confocal sensor



ISO size vials



Typically before annealing oven



Production optimization



Vimec V-Center software control

Vimec Applied Vision Technology B.V.

With over 30 years of experience in glass inspection and monitoring solutions, we are dedicated to designing, building, and validating visual inspection systems. Vimec offers a multitude of measurement possibilities to cover all your glass packaging inspection needs.

Interested?

Contact us for more information!

+31 (0)40 – 255 06 07

sales@vimec.nl

www.vimec.nl

Vimec Applied Vision Technology B.V.
proud member of **Kestrel Vision Group**

